

Oslo Narrow Commercial Letterbox

310

Contents

Your carton should contain the following parts:

- 1 x Letterbox
- 1 x Accessories Bag

IMPORTANT

Please carefully check your product(s) to ensure it has arrived in good order and condition prior to installation.

Choosing a Suitable Location

This letterbox can be mounted onto or into block and brickwork. It is advisable to follow AusPost recommendations, which say a letter slot must be located between 0.6 to 1.6m above the ground.

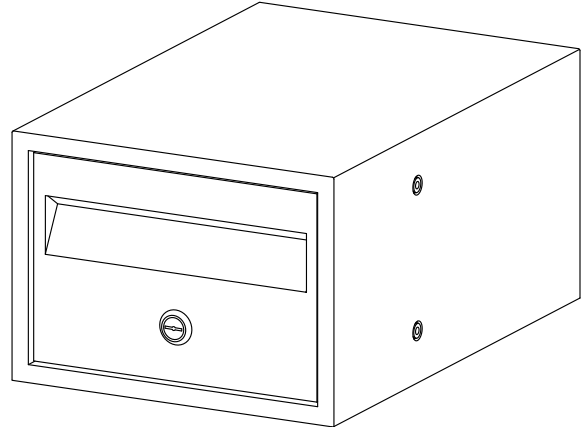

Assembling multiple letterboxes

We advise to pre-assemble each row of letterboxes prior to installation.

- a. Start with the first two letterboxes.

Remove the hole covers located in the left side of the right letterbox.

- b. Open the door of the right letterbox and visually align the mounting holes with the letterbox to the left of it.

- c. Insert the supplied bolts into each of the holes and tighten using a screwdriver.

- d. To complete the row, repeat steps a. to c. with the rest of the letterboxes.

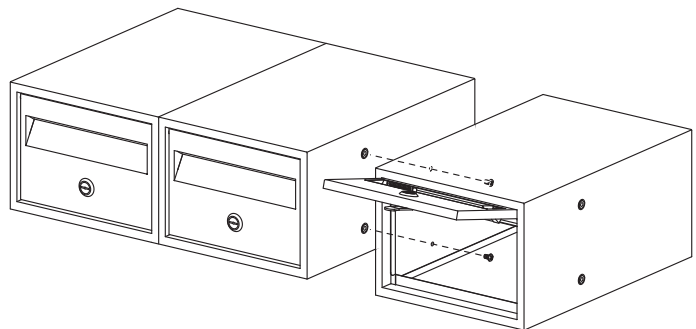
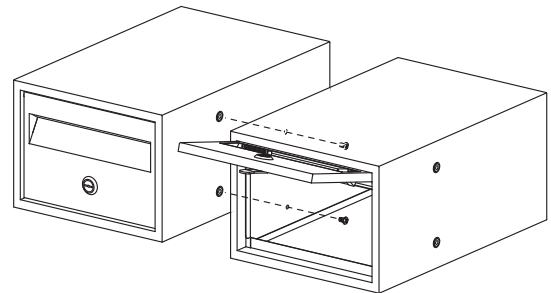

Installation INTO a brick wall

1. Build brickwork up to the desired level and place the 1st row of letterboxes.

Plain brick walls - the front face should sit flush with the wall.

Rendered walls - set the front face forward to allow for the render thickness.

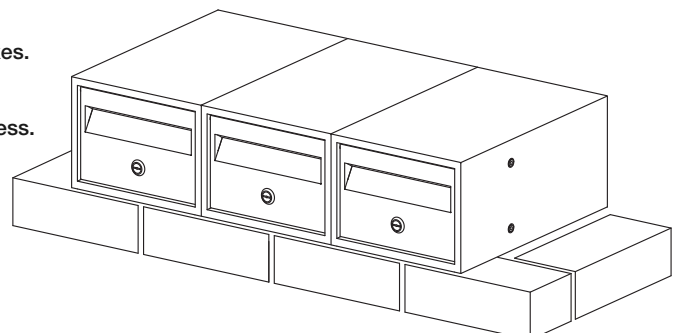

2. See next page

2. Apply construction adhesive on the top surface of the 1st row of letterboxes, then place the 2nd row on top. Repeat this step for the remainder of the rows.

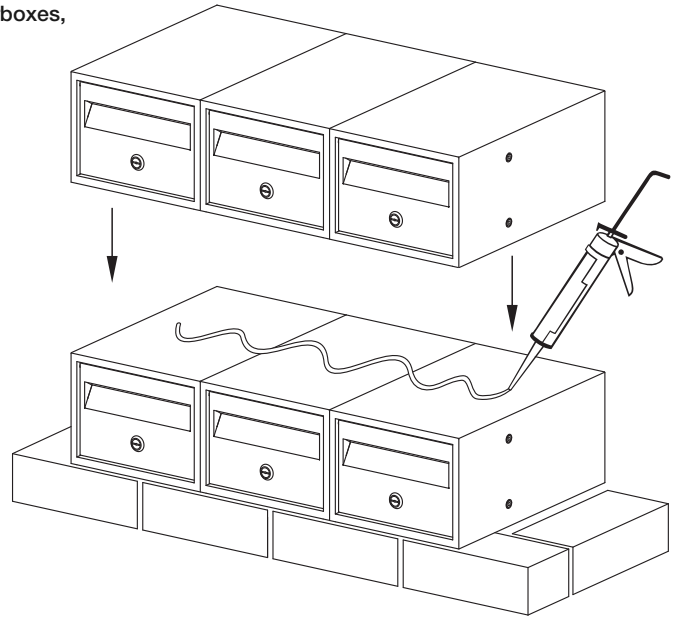

3. Once all letterboxes are in place, complete the remaining brickwork around the letterbox configuration.



IMPORTANT

If acid washing or rendering the brickwork, you must cover the letterbox configuration with a protective sheet. If you do not do this, the letterboxes will be at risk of damage and may void warranty.