

Sierra Fire Pit

Assembly Instructions

1. Secure the legs together with the bolts and nuts provided.

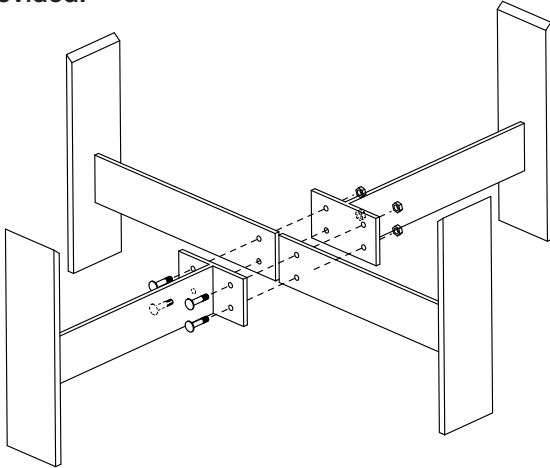

2. Place the bowl on the legs as shown

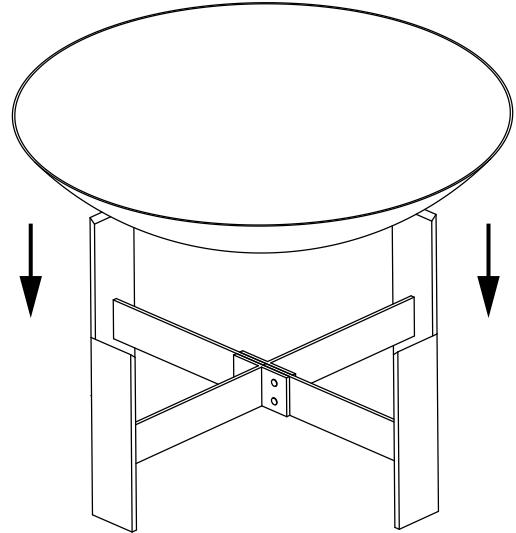

Instructions for Safe Use

- For residential use only, not for commercial use
- For outdoor use only (not indoor). Our fire pits should only be placed and used on heat resistant surfaces – our recommendations include gravel, crushed rock, sand, brick or clay pavers.
- We do not recommend placing your fire pit directly on concrete, grass, wood, composite decking, ceramic or porcelain tiles, due to the base of the fire pit generating high heat levels, and being in direct contact with these materials can affect the condition of the surface beneath.
- If your desired fire pit area includes concrete flooring, we would suggest adding an additional heat resistant layer between the fire pit and concrete such as brick or clay pavers.
- The fire pit should not stand closer than 5 metres from a timber wall
- The fire pit should not stand closer than 2.5m from any flammable material
- The fire pit is designed to burn timber and charcoal only
- Do not use any flammable liquids
- Build modest fires for the first few uses
- Do not use in high winds
- The fire pit will become very hot and must not be moved during use
- The fire pit must not be left unattended when in use
- Children must be supervised near the fire pit
- A water hose or fire-fighting equipment should be available when the fire pit is in use
- Make sure all embers are extinguished when finished with the fire pit
- When cool, clean all ash from the fire pit
- Ensure that it is legal to use the fire pit in your area
- Ensure that smoke emissions do not annoy your neighbours

Note: For products with rust finish, do not store or operate the fire pit in a location that may be affected by rust staining